



Series TT03C digital cap torque gauges are quick and economical solutions for basic handheld cap torque testing. These portable instruments eliminate the need to secure closures in a fixture or more elaborate testing system. A dedicated remote torque sensor with Jacobs chuck is supplied with a universal grip for caps from 0.65 - 1.55 in (16.5 - 39.4 mm) diameter (Series TT03C gauges consist of a Series TT03 torque gauge and G1053 cap grip).

Series TT03C records both application and removal torque values (clockwise and counter-clockwise directions), and is available in three capacities from 12 to 100 lbFin (135 to 1150 Ncm).

Series TT03C features a sampling rate of 2,000 Hz, producing accurate results under a wide range of test conditions. A backlit graphic LCD displays large characters, and a menu is available to access the gauges' features and configurable parameters. USB output is provided for data collection purposes.

Set point indicators are provided for pass-fail testing. The gauges are overload protected to 150% of capacity, and an analog load bar is shown on the display for graphical representation of applied torque.

The gauges include MESUR™ Lite data acquisition software, for tabulation of continuous or individual data points. One-click export to Excel button easily allows for further data manipulation.

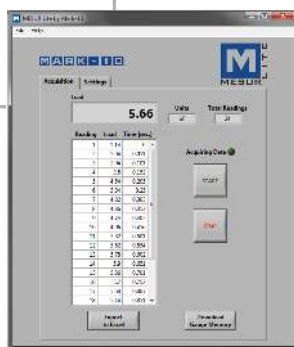

^ MESUR Lite data acquisition software is included with Series TT03C gauges



^ Universal cap grip and ergonomic sensor design makes testing a breeze



^ Optional AC1008 tabletop mounting stand

Features

- Universal grip accommodates broad cap size range
- Peak torque values saved and displayed
- High-speed 2,000 Hz sampling rate
- USB data output of continuous or individual data points
- Programmable set points with pass/fail indicators
- Live load bar graph with set point markers
- Peak CW and CCW readings always displayed
- Set points always displayed
- Configurable audio alarms and key tones
- MESUR™ Lite data collection software included

Display Indicators

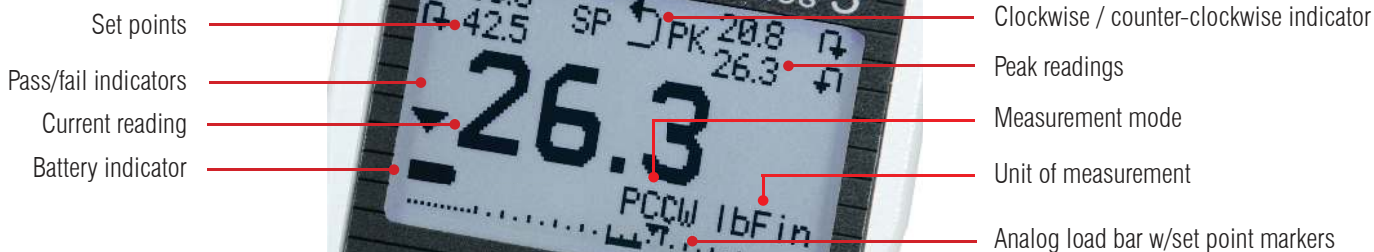

Specifications

Accuracy:	±0.5% of full scale ±1 digit
Sampling Rate:	2,000 Hz
Cap Diameter Range:	0.65 - 1.55 in [16.5 - 39.4 mm]
Power:	AC or rechargeable battery. Multi-step low battery indicator is displayed, gauge shuts off automatically when power is too low.
Battery Life:	Backlight on: up to 7 hours of continuous use / Backlight off: up to 24 hours of continuous use
Measurement Units:	lbFin, ozFin, Ncm
USB Output:	Configurable up to 115,200 baud
Safe Overload:	150% of full scale (display shows "OVER" at 110% and above)
Weight (without grip):	1.8 [0.8 kg]
Included Items:	Carrying case, universal voltage AC adapter, battery, quick-start guide, USB cable, resource CD (USB driver, MESUR™ Lite software, MESUR™ gauge DEMO software, and user's guide), and NIST-traceable certificate of calibration (certificate with data is available for an additional charge).
Environmental requirements:	40 - 100°F, max. 96% humidity, non-condensing
Warranty:	3 years (see individual statement for further details)

Dimensions in [mm]

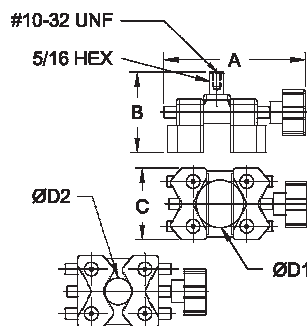
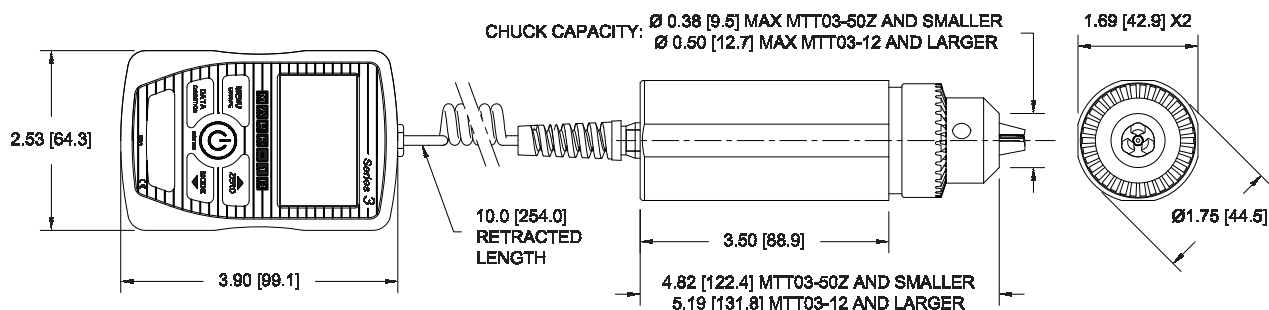

A	B	C	ØD1*	ØD2*
3.1 [78.7]	2.0 [50.8]	1.6 [40.6]	1.16 - 1.80 [29.5 - 45.7]	0.65 - 1.29 [16.5 - 32.8]

* Jaws must be reversed to switch from ØD1 to ØD2

Optional Items

AC1008	Tabletop mounting kit
CERT	Certificate of calibration with data

Capacity & Resolution

Model No.	lbFin	lbFin	Ncm
MTT03C-12	12 x 0.01	12 x 0.01	135 x 0.1
MTT03C-50	50 x 0.05	50 x 0.05	570 x 0.5
MTT03C-100	100 x 0.1	100 x 0.1	1150 x 1

All models include 110V AC adapters, unless ordered as below:
Add suffix 'E' for euro plug (220V), 'U' for UK plug (220V) or 'A' for Australian plug (220V).
Example: MTT03C-12E, MTT03C-50U, MTT03C-100A