

Utilisation - Use

Poids destinés à la vérification ou l'étalonnage des poids de classe M₁ et éventuellement de la classe M₂ et pour l'utilisation avec des instruments de pesage de classe II (précision fine).

Weights intended for use in the verification or calibration of class M₁ and possibly class M₂ weights and for use with weighing instruments of high accuracy class II.

Description - Description

Référentiel - Conformité : Recommandation OIML R111
Conformity : OIML R111 Recommendation

Caractéristiques Acier inoxydable :
Stainless steel specifications :

Masse volumique : 8000 ±100 kg/m³
Density



Rugosité : Rz(μm) < 5 - Ra(μm) < 1
Roughness

Susceptibilité magnétique :
Magnetic susceptibility

m < 1 g χ < -
2 g < m < 10 g χ < 4
m > 20 g χ < 0,8

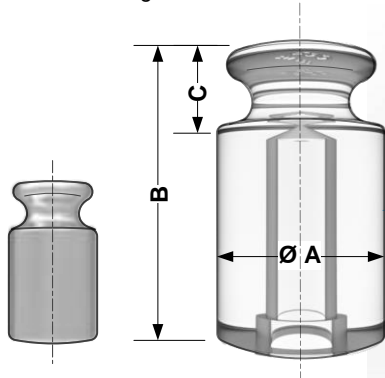
Magnétisation permanente : < 80 μT
Permanent magnetisation







Identification <i>Identification</i>	En option <i>Option</i>
	 ACCREDITATION N° 21218 MASSE Etalonnage <i>Calibration</i>

Nos accessoires - <i>Accessories</i>	
 Préhension <i>Handling system</i>	 660 000 Gants coton <i>Cotton gloves</i>
 Coffret bois <i>Wooden box</i>	 Valise plastique <i>Plastic case</i>

Caractéristiques techniques - Technical specifications

Poids avec cavité d'ajustage (sauf 1 à 20 g monobloc),
Identification pour assurer la traçabilité.

Weights with adjusting cavity (except 1 to 20 g monobloc)
- Identification for the traceability

Valeur nominale <i>Nominale value</i>	1 g	2 g	5 g	10 g	20 g	50 g	100 g	200 g	500 g	1 kg	2 kg	5 kg	10 kg	20 kg
Référence <i>Reference</i>	101 4613	102 4613	103 4613	104 4613	105 4613	106 4613	107 4613	108 4613	109 4613	201 4613	202 4613	203 4613	204 4613	205 4613
Ø A	6,0	6,0	8,0	10,0	13,0	18,0	22,0	28,0	38,0	48,0	60,0	80,0	100,0	140,0
B	6,0	10,4	14,4	18,0	21,6	30,8	40,5	51,3	66,2	83,0	104,0	144,5	183,5	193,5
C	2,8	2,8	3,9	4,6	5,6	8,0	11,0	12,5	17,0	22,0	28,0	37,0	47,0	64,0
EMT ± δm en mg <i>MPE ± δm in mg</i>	0,3	0,4	0,5	0,6	0,8	1	1,6	3	8	16	30	80	160	300
Système de préhension <i>Handling system</i>	666 0000 (100 mm) 						692 0000 (220 mm) 					669 0000	664 0000	665 0000
	670 0000 (150 mm) 								693 0000	695 0000	694 0000			

EMT : Erreurs Maximales Tolérées - MPE : Maximum Permissible Errors
Dimensions en mm - Dimensions in mm

ZWIEBEL SAS - SAINT JEAN SAVERNE - BP 50002 - F-67701 SAVERNE CEDEX
Tél. - Tel. : +33 (0)3.88.71.53.10 - E-mail : commercial@zwiebel.fr - www.zwiebel.fr