

DIAPHRAGM VACUUM PUMP LABOPORT® N 820 G



Technical features

- 100% oil-free transfer – thereby pure transferring, evacuation and compression of gases
- High level of vapor and condensate compatibility
- Ideal for extremely aggressive/corrosive gases and vapors
- ATEX compliant according to Ex II 2/-G IIB+H2 T3 internal atmosphere only
- Integrated gas ballast valve
- Expandable: Separators and/or condensers can be purchased individually at any time and easily fitted, enabling users to build their own customized vacuum system
- 3-color status display for in operation / stand-by / error
- Integrated rotational speed control
- Environmentally friendly
- Start against ultimate vacuum of the pump

Technical data

Flow rate [m ³ /h] at atm. pressure	1.2
Flow rate [l/min] at atm. pressure	20
Ultimate vacuum [mbar abs.]	6.0
Operating pressure [bar]	0.1
Voltage [V]	100 – 240
Frequencies [Hz]	50/60
Protection class	IP30
Power P ₁ [W]	60
Operating current [A]	0.35 (240 V AC) 0.66 (100 V AC)
With thermal switch and power fuse	

MATERIALS

Pump head	TFM™ PTFE
Diaphragm	PTFE-coated
Valves	FFPM

OTHER DATA

Weight [kg]	8.8
Hose connections	ID 9.5 – 8, PVDF
Dimensions W x H x D [mm]	163 x 220 x 259
Permissible media and ambient temperature [°C]	+5 to +40

ACCESSORIES AND SPARE PARTS

ACCESSORIES AND SPARE PARTS	ID
Spare parts kit	317435
Hose connector	317278
Key for hose connector*	316279
Silencer*	322528

*Part of the scope of delivery

Dimensions

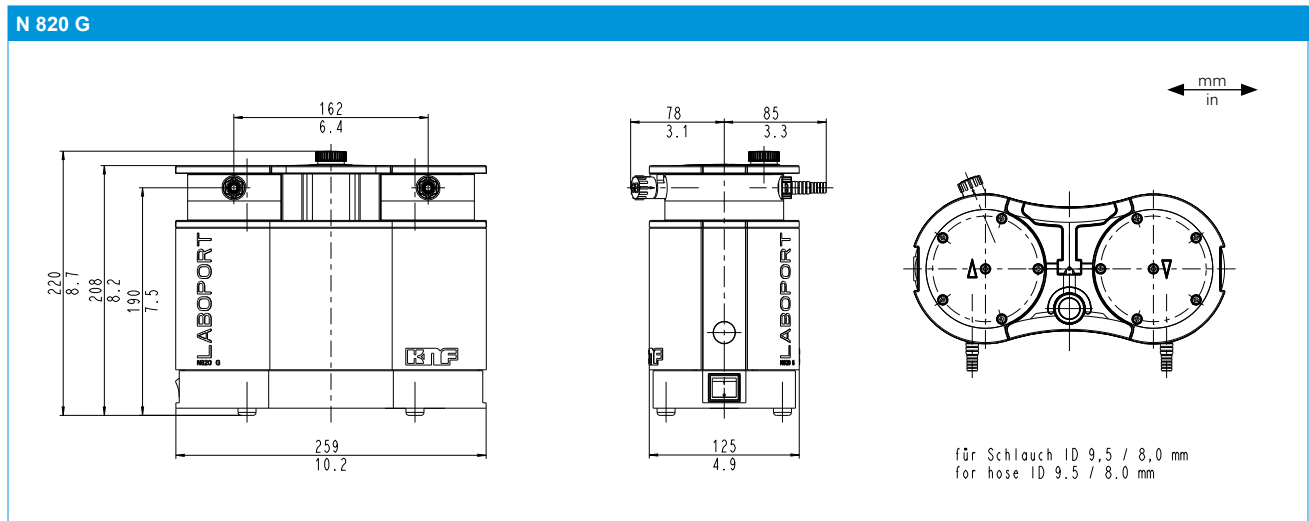

Performance characteristics

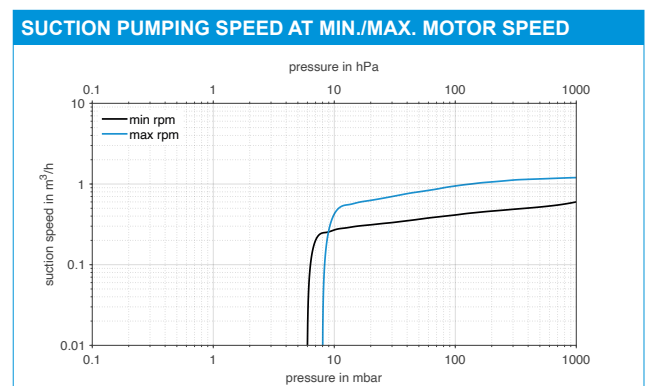
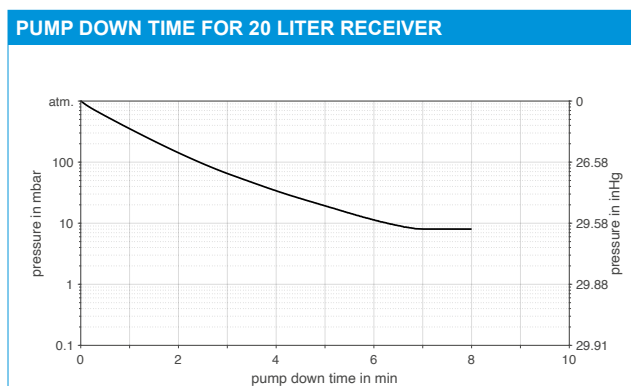

Modular expandable – from basic pump to system



CONVERSION KITS	ID
Conversion kit N 820 G in SR 820 G	339203/000000
Conversion kit N 820 G in SH 820 G	339199/000000
Conversion kit N 820 G in SC 820 G	337236/000000